

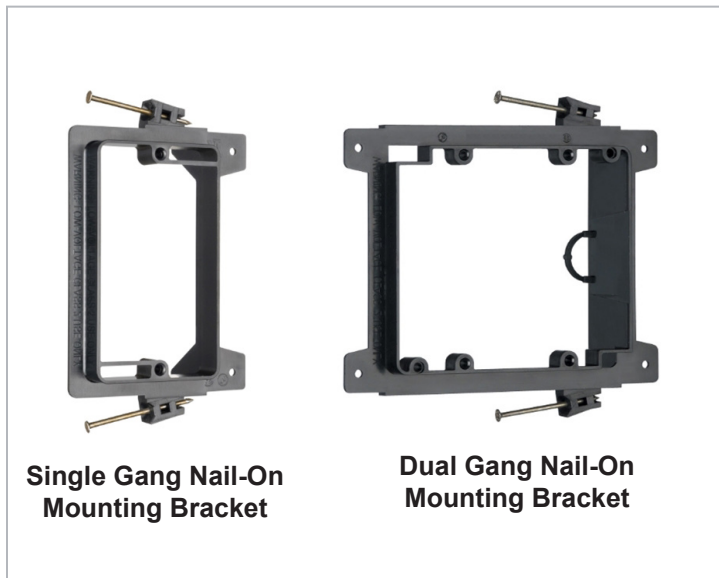

Nail On Mounting Bracket



Single Gang Nail-On Mounting Bracket

Dual Gang Nail-On Mounting Bracket

Applications

This nail on mounting bracket was designed for the professional installer to provide a simple and durable installation for a low voltage wall outlet in residential pre-wire or new commercial construction installations. These brackets are suitable for low-voltage- Class 2 wire only.

Description / Specifications

This UL Listed mounting bracket is available in black, in either single gang or dual gang and includes a built-in loop to tie off cable.

Ordering Information

Description	
Nail On Mounting Bracket	
Item Number	Type
XFPMB-05029	Single Gang
XFPMB-05030	Dual Gang

Features & Benefits

- Ideal for residential pre-wire or new commercial construction installations
- Suitable for use with Low-Voltage Class 2 wall outlet installations
- Built-in loop to tie off cable
- Available as a single gang or a dual gang nail-on mounting bracket
- UL- Listed
- Packaging: Sold Individually

Related Products

Reversible Single Gang Cable Entrance Faceplate

Item No. XFPLV-04850



High Speed VU Series With Ethernet, Black

- Item No. XHD01-04251 1.5 ft
- Item No. XHD03-04252 3 ft
- Item No. XHD06-04253 6 ft
- Item No. XHD10-04254 10 ft
- Item No. XHD12-04255 12 ft



CAT6 28Flex™ Snagless Patch Cables

Item No. RC6020XF-MYY

Specify Length by substituting XX in Item # for the following:  
 .5 = 0.5 ft, 01 = 1 ft, 02 = 2 ft, 03 = 3 ft, 04 = 4 ft, 05 = 5 ft, 06 = 6 ft,  
 07 = 7 ft, 10 = 10 ft, 14 = 14 ft, 15 = 15 ft, 20 = 20ft

Specify jacket color by substituting YY in Item # for the following:  
 BK = Black, BL = Blue, GY = Gray, GN = Green, WH = White, YE = Yellow



1.5" x 2.75" Nail On Safety Plate - Box of 100

Item No. XSFPL-05031

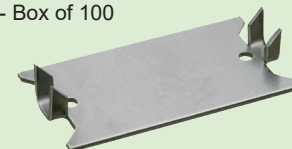



Nail On Mounting Bracket

Technical Drawing- Single Gang

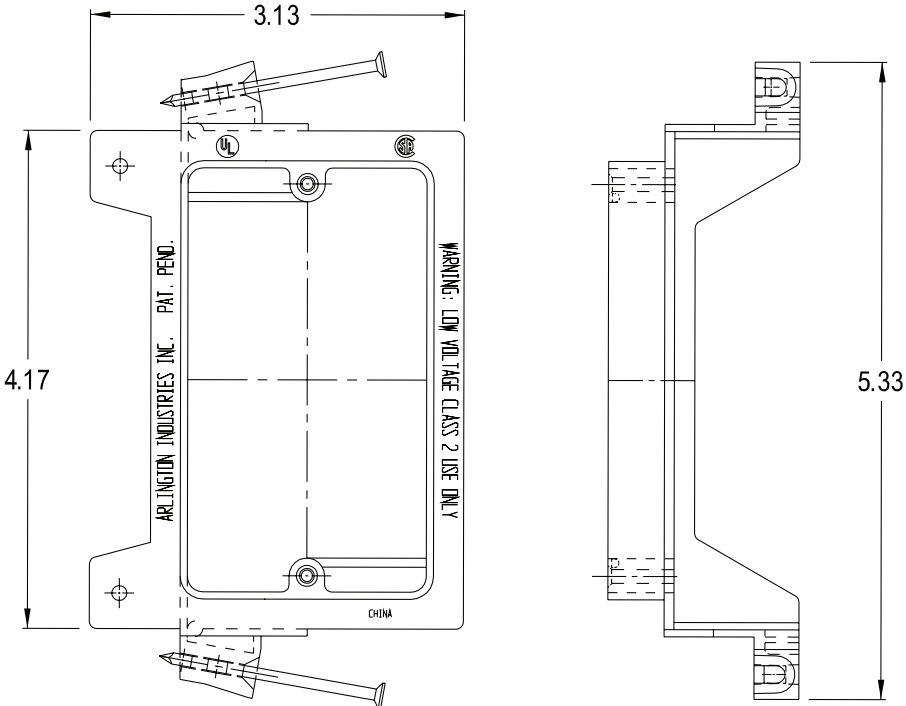

Technical Drawing- Dual Gang

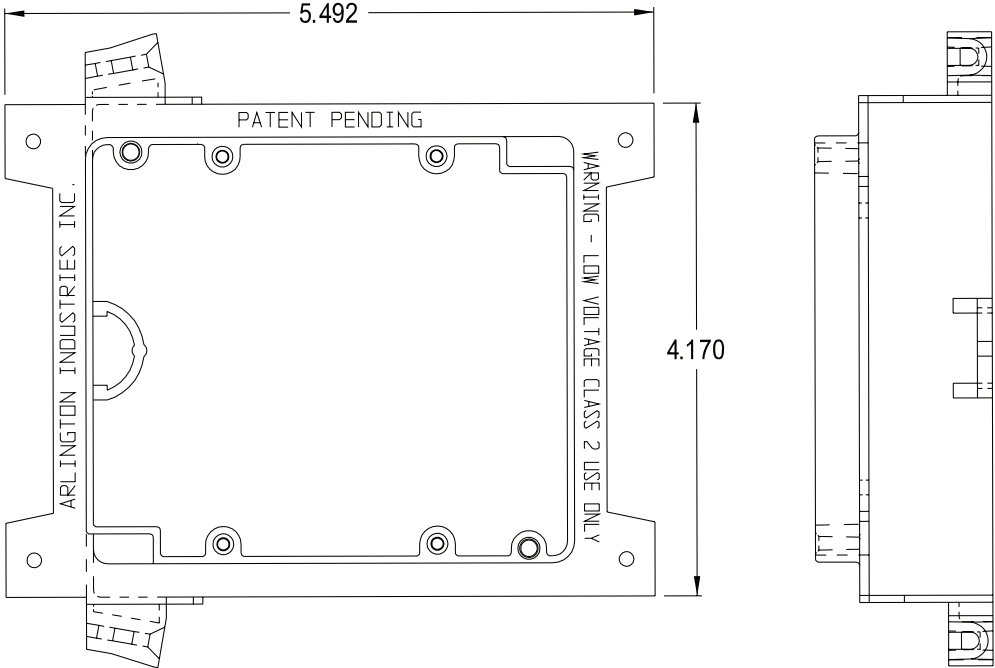

REV.20211221.2

TECHNICAL SHEETS ARE SUBJECT TO CHANGE WITHOUT NOTICE.