



Ceiling Mount for 5.1" - 12.6" Projectors



Applications

This ceiling mount is ideal for indoor, commercial or residential 5.1" - 12.6" projectors in situations where you want to mount your projector to the ceiling, while concealing assembly and mounting hardware for a finished professional appearance.

Description / Specifications

This ceiling mount fits most 5.1" - 12.6" projectors and supports up to 22 lbs. This ceiling mount for projections offers 360° rotation, while the 15° tilting allows for multi-angle projection in a variety of environments. Three support arms that can fit a wide range of mounting holes allows for flexible projector positioning. The quick release connector allows the projector to be installed quickly and easily released for maintenance, without the need for continuous re-alignment.

Features & Benefits

- Mounting Range: 5.1" - 12.6" (130-200mm)
- Tilts 15° in either direction for easy angle adjustment
- Rotates 360°
- Simple to install
- Decorative cover conceals assembly and mounting hardware for a finished appearance
- Hidden cable management integrated in pole beneath channel covers
- 2 different height tubes included to accommodate different height levels
- Limited 10 Year Warranty

Construction

Product Material: Aluminum

Surface Finish: Sand-Blasted Aluminum Anodic Oxidation

Color: Black

Integrated Cable Management: Yes

Integrated Bubble Level: No

Physical

Weight Capacity: 22 lbs (10 kgs)

Dimensions: 7.9" x 13.3" x 13.3" (20.1cm x 34cm x 34cm)

Tilt Angle: ±15°

Rotation: 360°

Profile to Ceiling: 5.1" - 7.9" (12.7mm - 20mm)

Installation Requirements: Ceiling, Single Stud

Technical Illustration

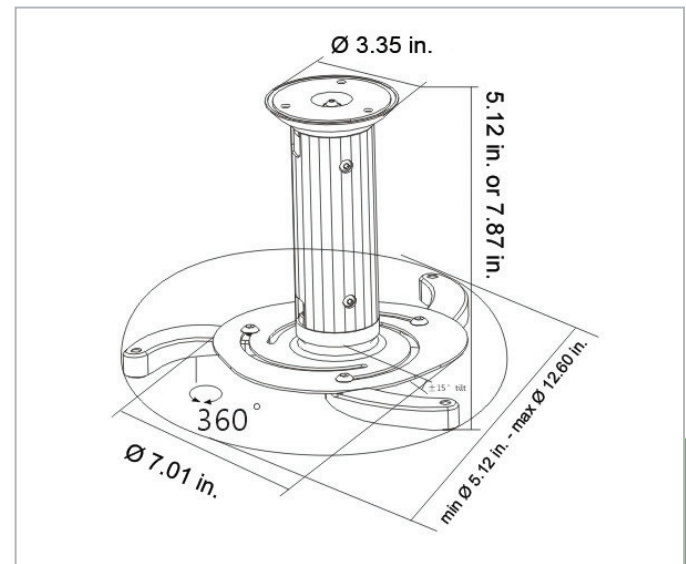

Ordering Information

Description	
Ceiling Mount for 5.1" - 12.6" Projectors	
Item Number	Motion
VMCPJ-04787	Tilts & Rotates