

COMPLIANCE	ANSI/EIA RS-310D IEC60297-2 DIN41494; Part 1 DIN41494; Part 7
LOADING CAPACITY	3,000 lbs static load

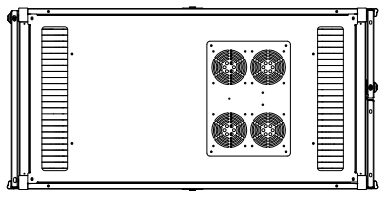

TOP VIEW

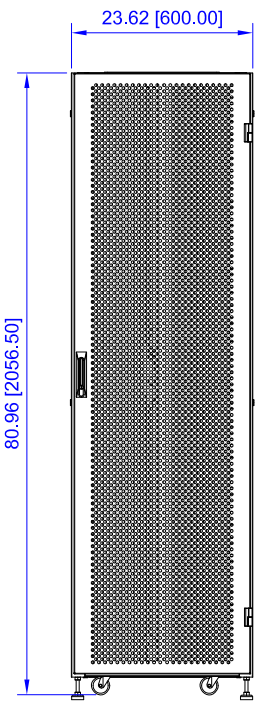
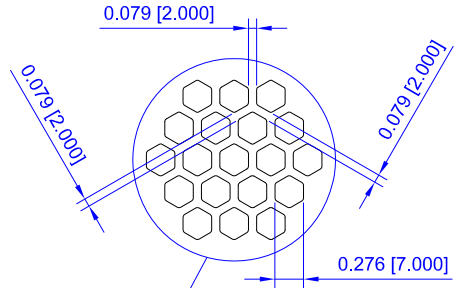

FRONT VIEW

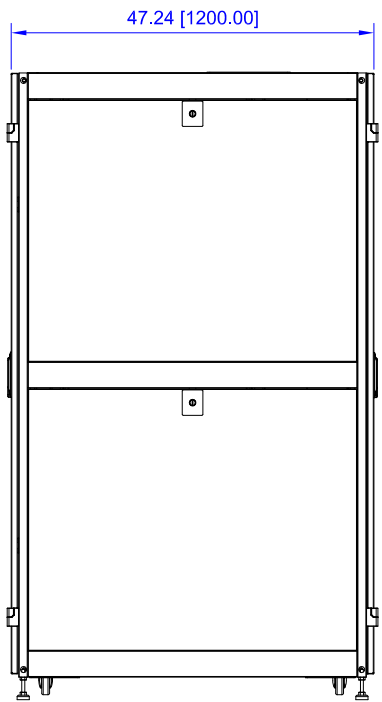

SIDE VIEW

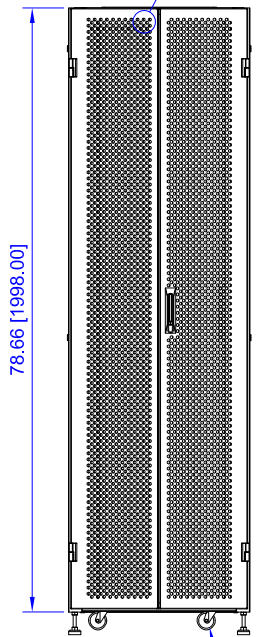

BACK VIEW

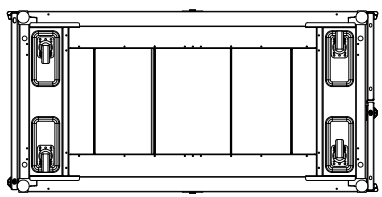

BOTTOM VIEW

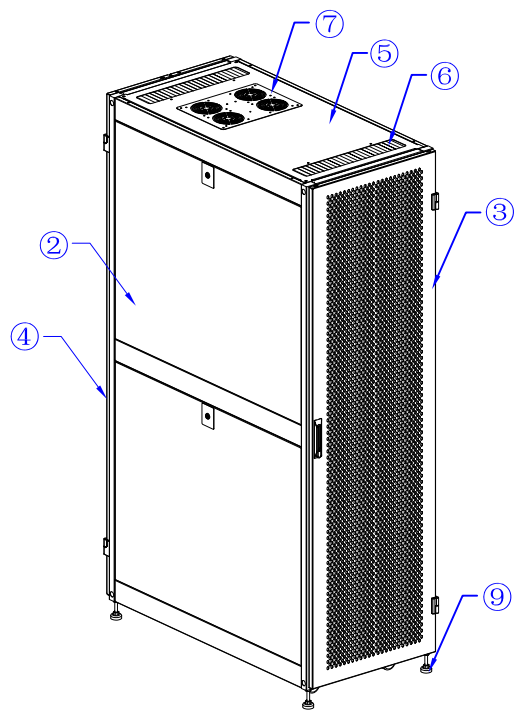

12	2	PDU Lacing Panels	Steel	18 gauge
11	4	Cage Hole Mounting Rails	Steel	14 gauge
10	4	2.5" Dia. Casters		
9	4	Adjustable Levelers		
8	2	Adjustable Bottom Panels	Steel	18 gauge
7	1	Removable Fan Panel	Steel	18 gauge
6	2	Brush Panel Cable Entry		
5	1	Top	Steel	18 gauge
4	1	Split Panel Mesh Rear Door (standard)	Steel	18 gauge
3	1	Full Panel Mesh Front Door (standard)	Steel	18 gauge
2	4	Removable Side Panels	Steel	16 gauge
1	N/A	Cabinet Frame	Steel	18 gauge
NO	QTY	NAME	MATERIAL	THICKNESS

ITEM NO.		VC5-6242-ABV1A*		<b>VERICOM</b>	
DESCRIPTION					
42U x 48"D SERVER CABINET					
DATE	SCALE	SHEET	REV		
04/14/20	none	1 of 2	1		

\*VC5-6242-ABV1A replaces RS2AB42-BV1A

All dimensions in inches [mm]

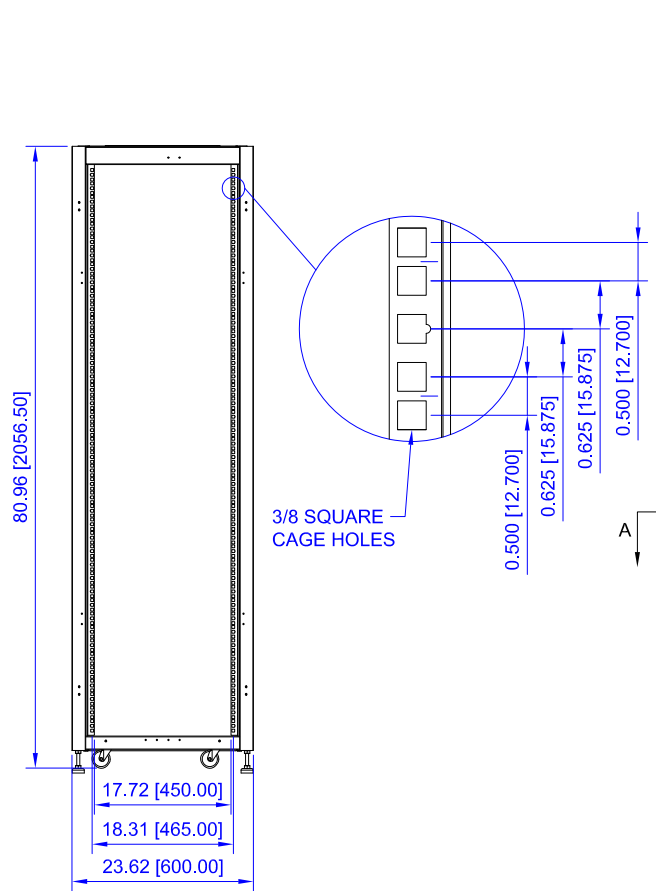

FRONT VIEW  
(NO DOOR)

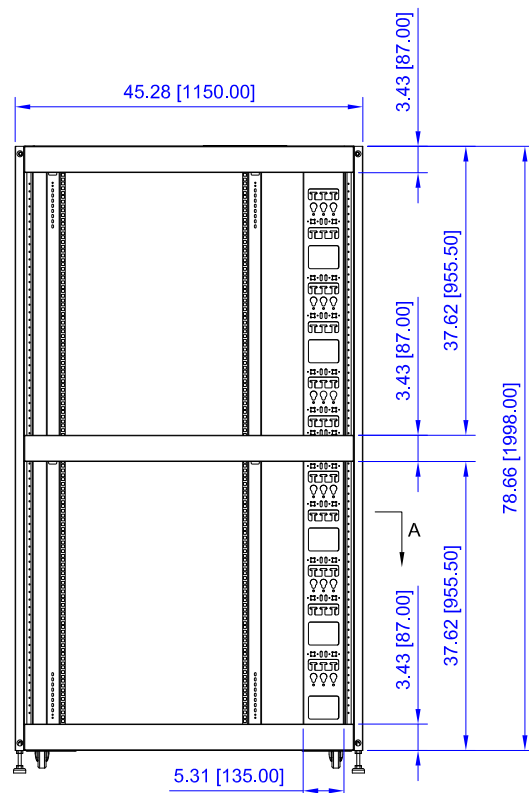

SIDE VIEW  
(NO SIDE PANELS)

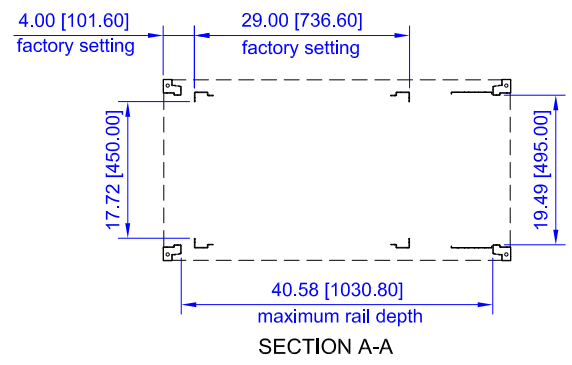

SECTION A-A

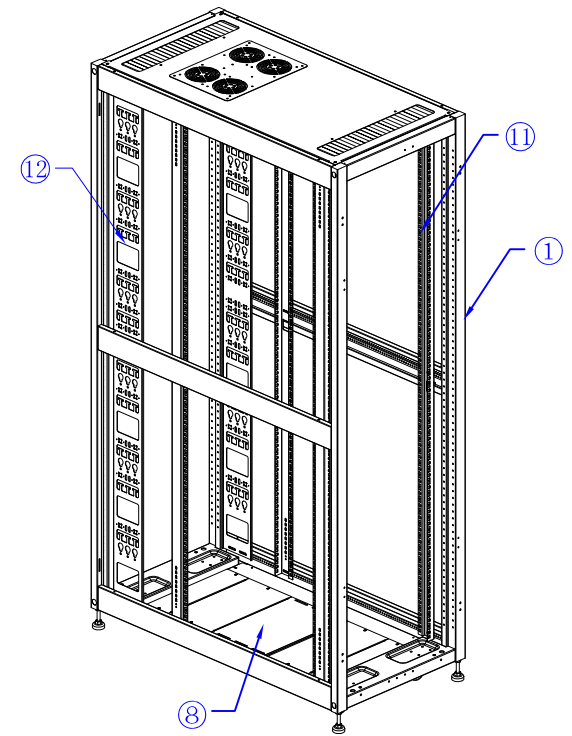

ITEM NO.	VC5-6242-ABV1A*		<b>VERICOM®</b>	
DESCRIPTION	42U x 48"D SERVER CABINET			
DATE	SCALE	SHEET	REV	
04/14/20	none	2 of 2	1	

\*VC5-6242-ABV1A replaces RS2AB42-BV1A

All dimensions in inches [mm]