



Hinged Wall Mount Brackets



Description

This product is designed to provide a cost-effective solution for mounting patch panels or other networking equipment to a wall. The open design allows for ambient cooling, while the universal hinge design can be mounted on the left or the right side and allows equipment to swing out 160°. This hinged wall mount bracket is available in 1U, 2U, or 4U sizes and features 16" spacing of keyholes for easy mounting to wall studs, through the wall cable access via cut out holes, and a folded edge, U-shaped construction for added strength and stability. Optional top cover plate available. Wall mount hardware not included.

Product Specifications

- Product Type:** Hinged Wall Mount Bracket
- Material:** 16 Gauge Cold Rolled Steel
- Finish:** Black Powder Coated
- Loading Capacity:** Varies By Item #
- No. of Pieces:** 1
- Finish:** Black Powder Coated
- Dimensions (HxWxD):** Varies By Item #
- Unit Weight:** Varies By Item #
- Rack Unit Quantity:** 1U, 2U or 4U
- Mounting Hardware:** Included
- Compliance & Standards:** ANSI / EIA RS-310D & RoHs Compliant
- Quantity Per Package:** Sold Individually
- Carton Dimensions (HxWxD):** Varies By Item #
- Carton Weight:** Varies By Item #

Ordering Information

Description						
Hinged Wall Mount Bracket						
Item #	Rack Units	Loading Capacity	Unit Dims (HxWxD)	Unit Weight	Carton Dims (HxWxD)	Carton Weight
VB1-011	1U	11 Lbs.	1.87" X 20.5" X 6.7"	2.2 Lbs.	2.375" X 21.25" X 7.875"	4.4 Lbs.
VB1-021	2U	17 Lbs.	3.63" X 20.5" X 6.7"	3.3 Lbs.	4.75" X 21.25" X 7.875"	5.5 Lbs.
VB1-041	4U	17 Lbs.	7.11" X 20.5" X 6.7"	5.5 Lbs.	8.7" X 21.25" X 7.875"	7.7 Lbs.



Hinged Wall Mount Brackets

Technical Drawing: 1U

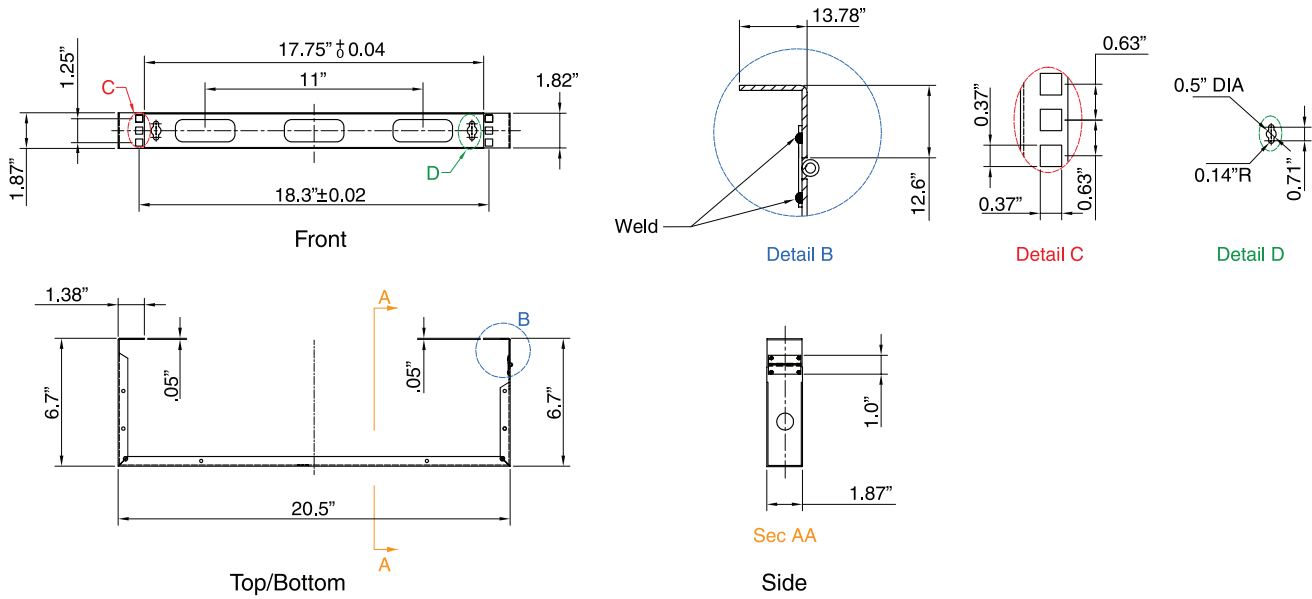

Technical Drawing: 2U

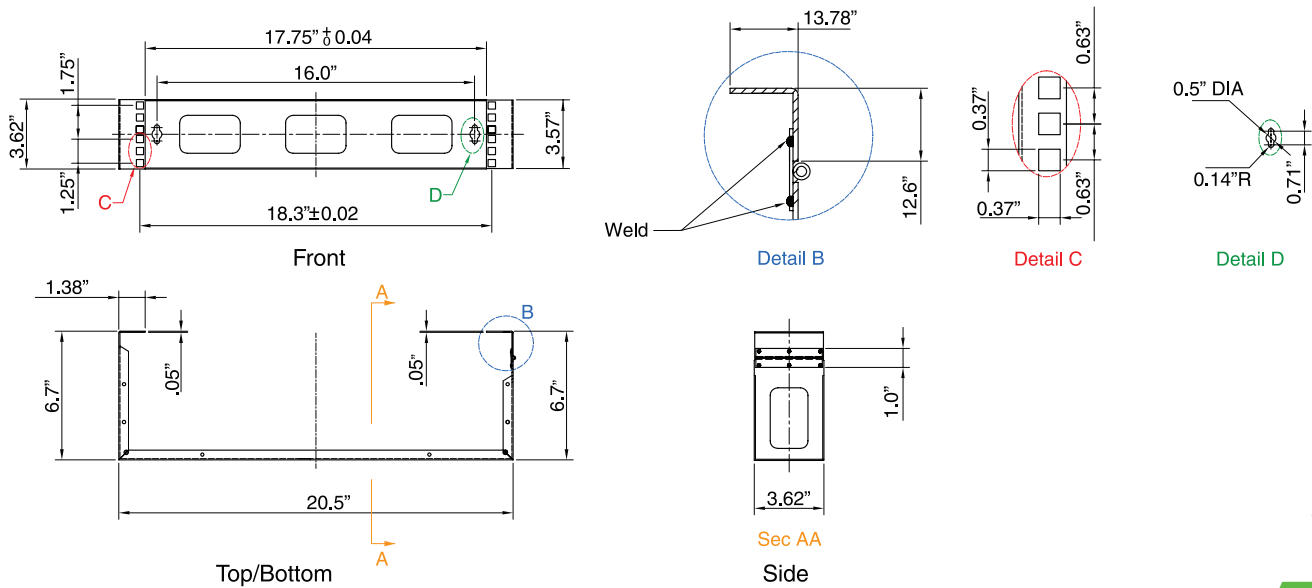

Hinged Wall Mount Brackets

Technical Drawing: 4U

