



Top Mount Quad Fan, 300 CFM



Description

The Top Mount Quad Fan can be added to any Vericom Network, Server, or SOHO cabinet to provide the additional airflow required to keep equipment running cool. Powerful yet quiet, this fan is a great option for installations in any environment.

Technical Drawing

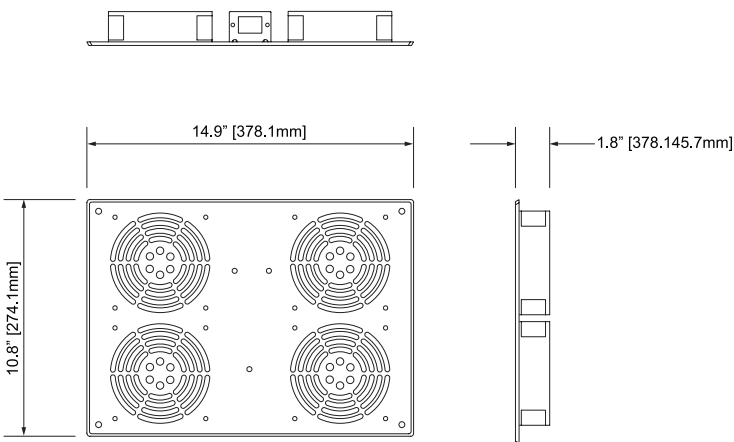

Product Specifications

- Product Type:** Electric Fan
- Impeller Material:** PBT Reinforced Plastic
- Terminals:** 0.02"
- Dimensions (HxWxD):** 1.9" x 14.9" x 10.8"
- Motor:** Shaded Pole Induction Motor
- Bearing System:** Sleeve
- Cord Length:** 6 ft (*Detachable*)
- Operating Temperature:** -10°C ~ 70°C
- Voltage:** 100 ~ 125 VAC
- Frequency:** 50 / 60 Hz
- Current:** 0.96 Amps
- Power:** 10 / 9 Watts
- Speed:** 2100 / 2400 RPM
- Noise:** 160 dBA
- Airflow:** 300 CFM
- Static Pressure:** 3.1 / 4.1 (mmH²O)
- Weight:** 6.50 lbs
- Quantity Per Package:** 1

Ordering Information

Item #	Description
RAFNQ04	Top Mount Quad Fan, 300 CFM